

Logan 8" Shaper Feed Clamp Parts

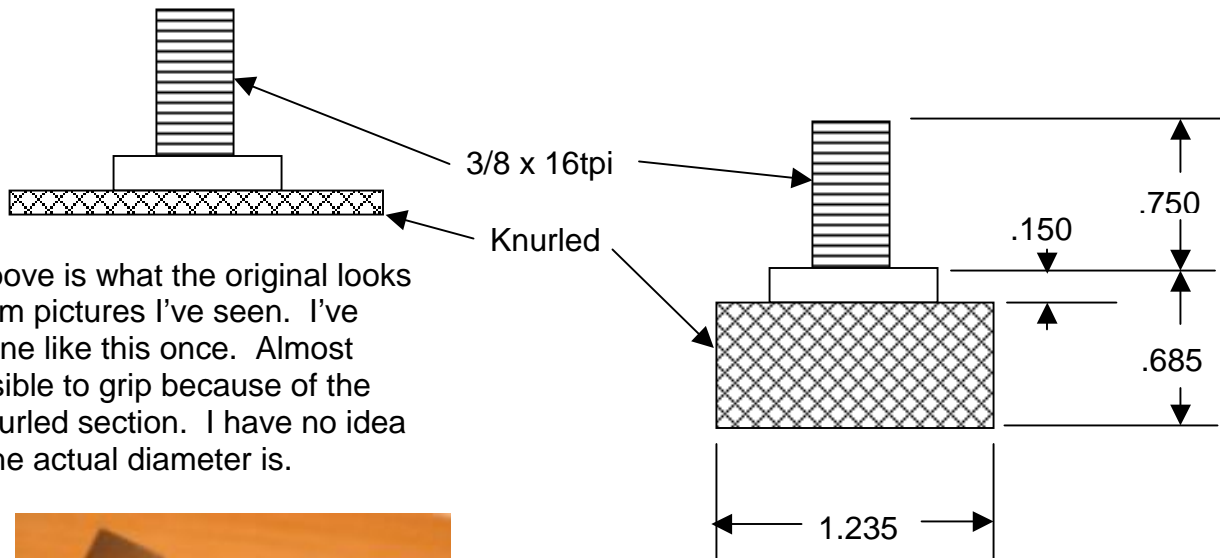

The above is what the original looks like from pictures I've seen. I've used one like this once. Almost impossible to grip because of the thin knurled section. I have no idea what the actual diameter is.

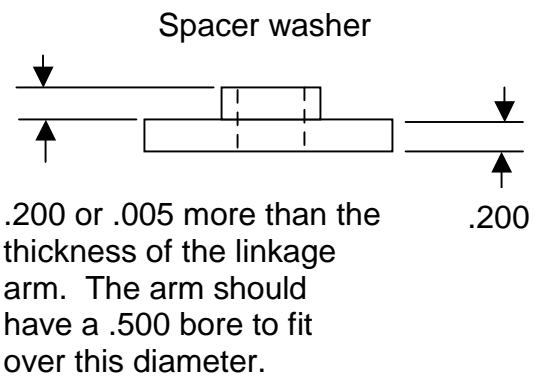
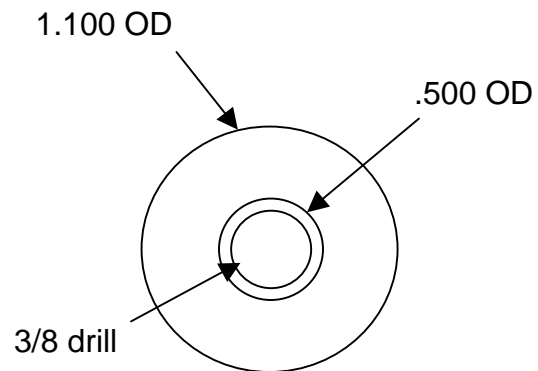
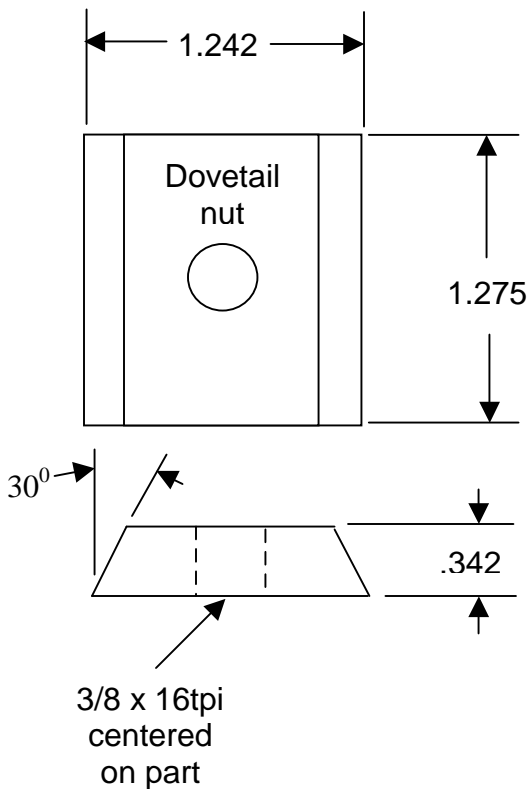

The above is what I made years ago not knowing what an original looked like. Only thing I would change is to make the diameter 1.500. I would keep the width for sure.